



*Chuck not included

The perfect automated solution for lifting, tilting and rotating workpieces of various capacities, shapes and sizes 360 degrees. Our cost-effective, robust and reliable LCVP range of positioners are designed to significantly increase the quality and consistency of your weld, by hand and automation.

SPECIFICATION	LCVP500
Safe Working Load	500kg
Centre of Gravity & Eccentricity (C of G & Ecc)	200mm/100mm
Degree of Tilt	135°
Degree of Rotation	360°
Tilting Speed	67 secs
Rotation Speed	0.15 - 1.5 rpm
Height to Table Horizontal	600mm
Height to Table Vertical CL	485mm
Table Dimensions	600mm
Table Type	Round
Table Slots	4 x 14mm (M12)
Earthing	800 amps
Control Pendant	Yes
Incoming Supply	400V - 3Phase - 50Hz
Weight	325kg
Foot Print (L x W x H)	1100mm x 760mm x 600mm

Key Plant is a global leader in the design and manufacture of weld automation equipment and more.

We Sell, Rent and Lease our innovative welding and positioning equipment - all over the world.

We are industry gamechangers, Can't find what you require? or need a larger capacity? Contact a Key Plant specialist today.



+44 (0)1538 388 388



+1 (832) 770 9173

sales@keyplant.com

www.keyplant.com

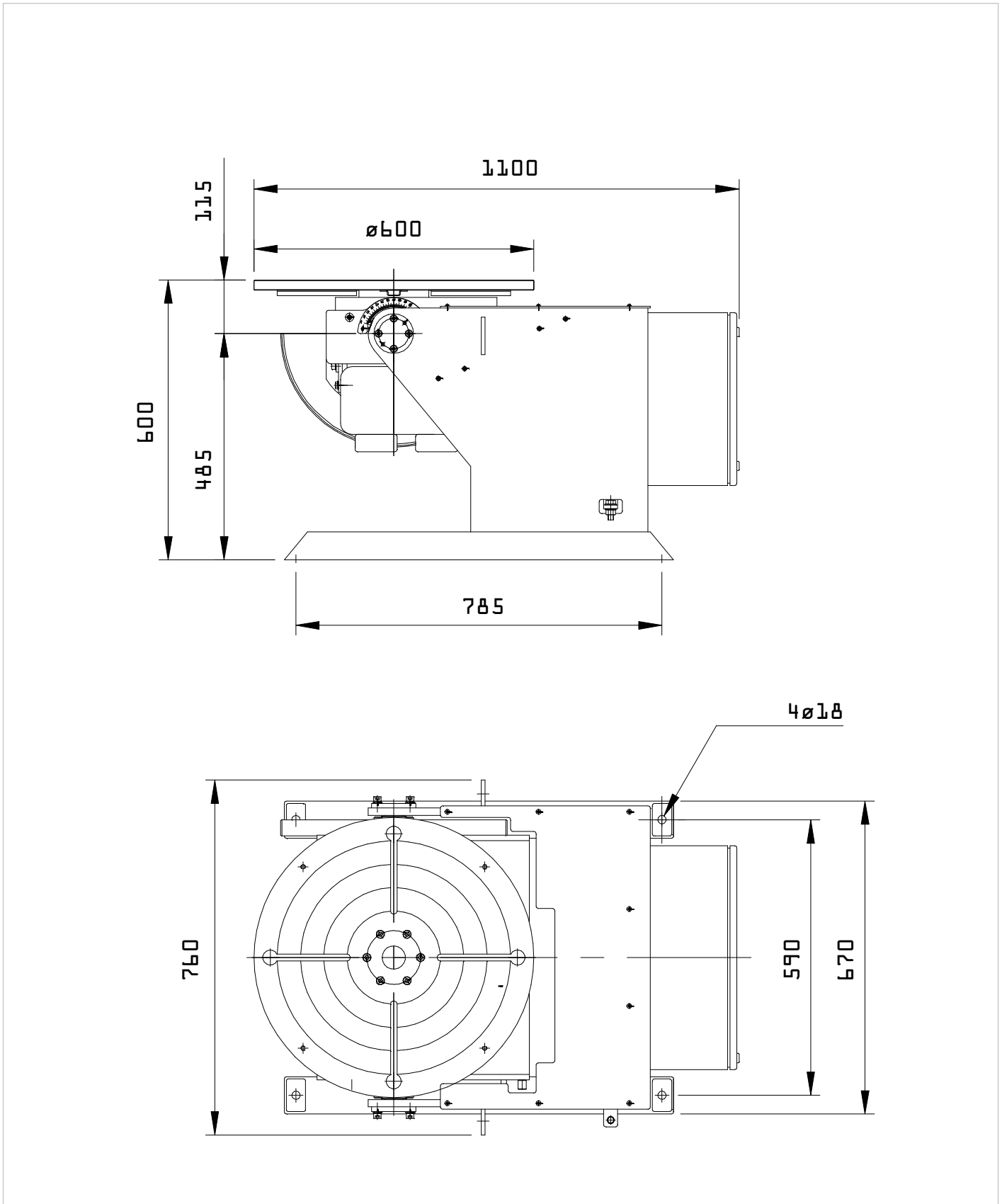

Key Plant is a global leader in the design and manufacture of weld automation equipment and more.

We Sell, Rent and Lease our innovative welding and positioning equipment - all over the world.

We are industry gamechangers, Can't find what you require? or need a larger capacity? Contact a Key Plant specialist today.

