

AUTOMATIC ROTARY WELD POSITIONER

Gullco Welding Positioners are positive drive rotary turn tables complete with mounting flange, drive and tilt mechanisms and microprocessor based pulse width modulation motor controls. Standard and Programmable models are available. They are driven by a low voltage permanent magnet motor and gear head power unit assembly. The microprocessor motor control enables operator interface of start, stop, clockwise rotation and infinitely variable control of the speed, within the range of the model.

Rotation speed is electronically controlled using an optical tachometer located on the back of the gear-motor. Speeds within the range of the model are infinitely variable in both clockwise and counter-clockwise directions through a rotary speed adjustment potentiometer located on the remote control. Table tilt is manually set at any desired angle, from 0° through 90°, quickly and easily. Safety is greatly enhanced with Gullco low voltage (24 V) control and power supply system.

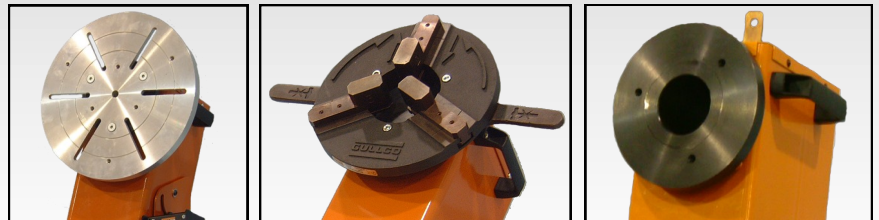

Increase Productivity, Quality and Profitability

AVAILABLE WITH 2" THROUGH HOLE FOR LONGER WORK PIECES



WELDING AND CUTTING AUTOMATION

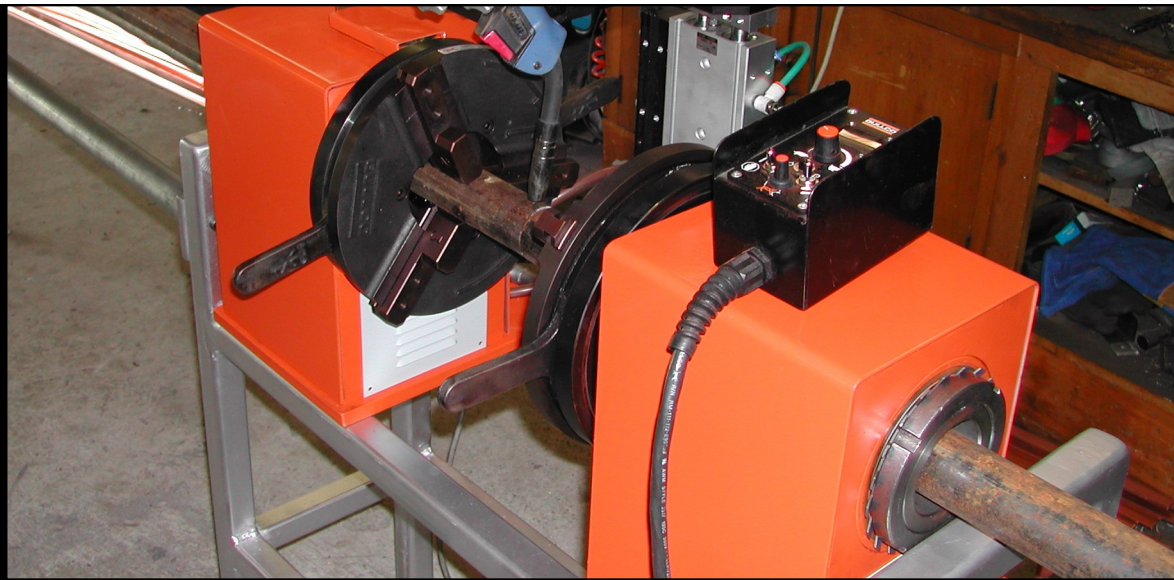

GULLCO Welding Positioners

GP/GPP 200 SERIES POSITIONERS ARE AVAILABLE IN STANDARD OR PROGRAMMABLE MODELS WHICH ARE EQUIPPED WITH CORRESPONDING REMOTE CONTROLS

STANDARD

The Standard Remote Control provides

- infinitely variable rotation speed within the model's speed range,
- forward/neutral/reverse switch,
- run/stop switch
- speed potentiometer



PROGRAMMABLE

The Programmable Remote Control with LED readout provides

- infinitely variable rotation speed within the model's speed range,
- forward/neutral/reverse switch,
- run/stop switch
- **programmable microprocessor** providing adjustable positioning timing cycles, amount of weld rotation, weld on/weld off through 360° and a signal to activate a pneumatically operated weld gun holder and wire feed arc activation.



FOOTSWITCHES (optional)

Three footswitch models are available;

GP-200-024 - Run/Stop footswitch assembly for manual operation. This kit provides a run/stop footswitch; a footswitch guard cover; a connecting control cable; and strain relief glands. When activated, the footswitch will provide a run signal to the control.

GP-200-025 - Variable Speed footswitch assembly for manual operation. This kit provides a run/stop/variable speed footswitch; a footswitch guard cover; a connecting control cable; and strain relief glands. When activated, the footswitch will provide a run signal to the control and allow regulation of the rotational speed via the compression of the footswitch pedal.

GP-200-023 - Forward/Stop/Reverse footswitch assembly for manual operation. This kit provides a directional footswitch; a footswitch guard cover; a connecting control cable; and strain relief glands. When activated, the footswitch will provide a run signal and rotary direction signal to the control.



PURGE-EQUIPPED MODELS:

have a 1/4" (6.4 mm) hole through the centre of the table drive shaft and a gas rotary coupling mounted on the underside of the table ... the shaft having a 1/4" NTP tapped gas inlet hole.



GULLCO SELF-CENTERING WELDING GRIPPER

(optional)

The Gullco **WPG-250** Gripper is quickly and easily mounted on any make of positioner, turntable or tailstock. They are slim but rugged... weighing only about half that of a standard chuck, minimizing reduction in positioner capacity. Single lever provides smooth, positive self-centering "close/open" action.



MOUNTING TABLE (optional)

Gullco GP-200-016 12" (305mm) diameter mounting table. This round mounting table is used to facilitate direct mounting of components or fixtures and provides (6) radial mounting slots and various three (3) hole pitch circle bolt patterns. The mounting table is quickly and easily mounted on the positioner spindle flange.

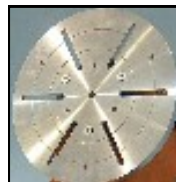

Gullco offers a wide range of accessories that provide low cost welding/cutting automation solutions including...



KR-1000 & 2000 WSB

KR-1000 WSB...free standing support and welding gun holder assembly. 1-1/8" (28.6mm) square rack arms and rack boxes provide 11-1/2" (292.1mm) of vertical adjustment and 10-1/2" (266.7mm) of horizontal adjustment. Supplied with swivel mounted, adjustable gun holder assembly.

KR-2000 WSB Same as above, except uses 1-1/2" (38.1mm) rack arms and rack boxes and provides 7-1/2" (190.5mm) of vertical and 6-1/2" (165.1mm) of horizontal adjustment.

KR-1000 CSB & KR-2000 CSB are the same as above except they are supplied with swivel mounted, standard rack-type cutting torch holder instead of welding gun holder

CUSTOMIZED AUTOMATION

The above cutting torch and welding gun support assemblies can be, and often are, equipped with one or two Gullco motorized rack arms controlled by a remote joystick pendant.



KR-1000 & 2000 CSB

Model GP-300/350 "Through Hole" Positioners

These positioner models are designed with a 2.5 inch (63 mm) "through hole" so the workpiece can be passed through the unit... making production on long pieces easier and faster.

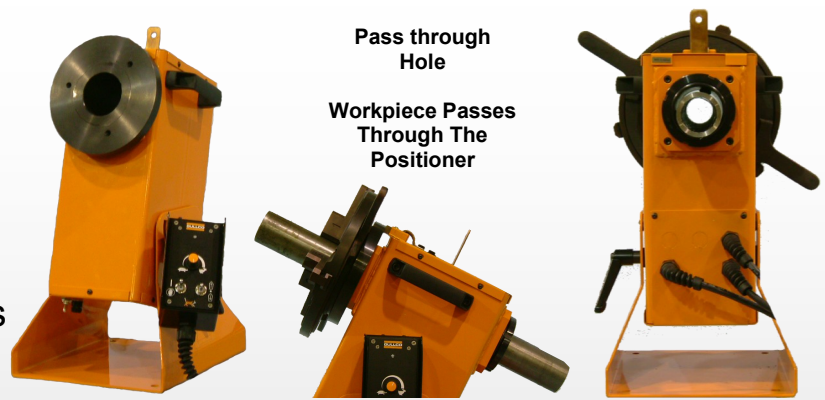

Pass through Hole

Workpiece Passes Through The Positioner

SPECIFICATIONS

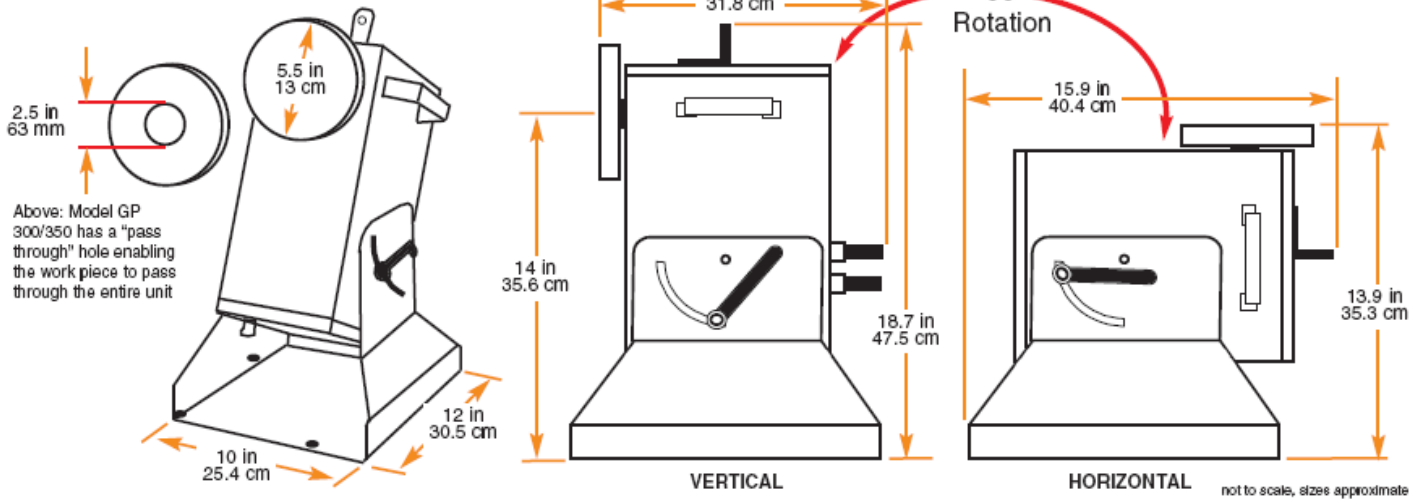

LOAD CAPACITY/SPEEDS

Models:

GP/GPP-(200 & 250)-M and GP (300 & 350)-M

(Speeds 0.27 to 4.63 RPM) 150 lbs. (68 kg) at 3" (76 mm) center of gravity and 3" (76 mm) eccentricity with the table in the vertical position...300 lbs. (136 kg) with the table horizontal.

Models:

GP/GPP-(200 & 250)-H and GP (300 & 350)-H

(Speeds 0.75 to 12.5 RPM) 75 lbs. (34 kg) at 3" (76 mm) center of gravity and 2" (51 mm) eccentricity with the table in the vertical position...150 lbs. (68 kg) with the table horizontal.

TABLE ROTATION

Electronically controlled, infinitely variable in either direction. Positive drive.

TABLE TILT

0° through 90°

ROTATIONAL TORQUE

GP/GPP-(200 & 250)-M and GP (300 & 350)-M 450 inch lbs. (518 kg.cm)

GP/GPP-(200 & 250)-H and GP (300 & 350)-H 150 inch lbs. (172 kg.cm) through the speed range. The maximum allowable eccentricity of centre of gravity of the work piece for a given load in inches is calculated as follows.

150
weight of work in lbs.

The weight must not exceed the values for overhung load ratings shown below.

(D) Distance		(L) Load	
IN.	MM.	LBS.	KGS.
3	76	150	68
6	152	97	44
9	229	72	33
12	305	57	26

Model	Gas Purge	Programmable	Rotational Speed	Vertical Table Loading @ 3" C of G	Horizontal Table Loading
GP-200 & 300-M			0.27 - 4.63 RPM	150 lbs. (68 kg.)	300 lbs. (132 kg.)
GPP-200-M	■				
GP-250 & 350-M		■			
GPP-250-M	■	■			
GP-200 & 300-H			0.75 - 12.5 RPM	75 lbs. (34 kg.)	150 lbs. (68 kg.)
GPP-200-H	■				
GP-250 & 350-H		■			
GPP-250-H	■	■			

AUTOMATIC POSITIONER ROTARY WELD SYSTEM

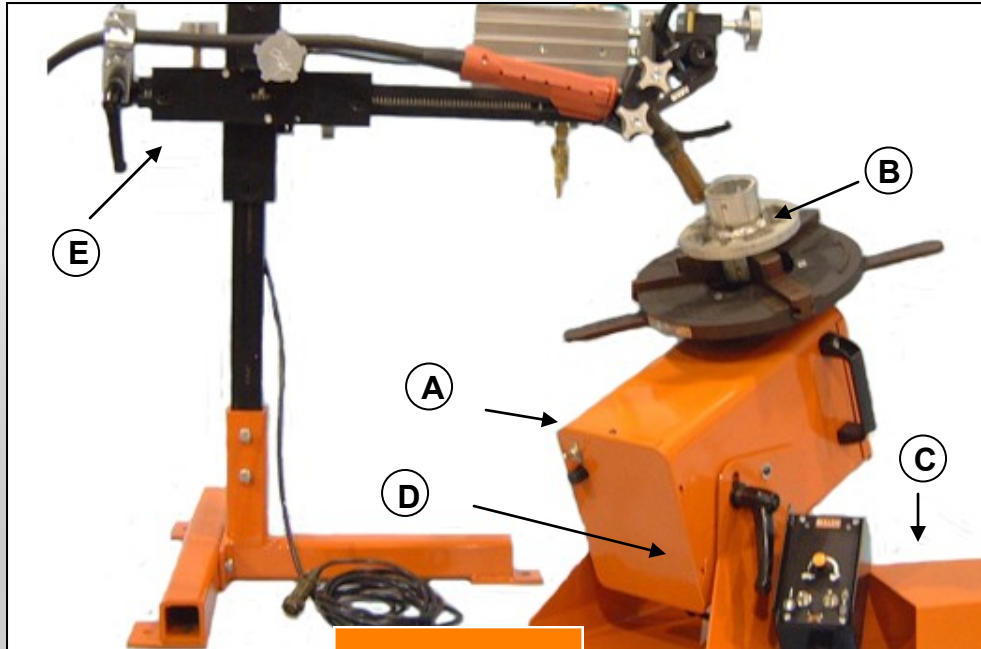

GULLCO

ITEM DESCRIPTION

- A - Welding Positioner
- B - 3 Jaw Gripper
- C - Footswitch Assembly for Manual Operation
- D - Wire-feed/Arc Start Signal Kit
- E - Pneumatic Gun Positioning Assembly

AN ACCURATE AND RELIABLE AUTOMATIC ROTARY WELD PRODUCTION SYSTEM FOR A FRACTION OF THE PRICE OF A P.L.C./SERVO SYSTEM.

Gullco's new microprocessor control not only provides improved speed regulation to Gullco's proven "GP" range of positioners. It also allows the positioner to be expanded into a fully automated welding cell. The control uses a tach feedback system to ensure smooth and accurate rotation of the workpiece and has the ability to activate pneumatic welding gun holder and wire-feed/arc activation signals, based on an operator defined welding cycle. The programmable microprocessor also provides adjustable positioning timing cycles, amount of weld rotation and weld on/off through 360°.

KAT, MOGGY, KATBAK & SAM are registered trademarks of Gullco Enterprises

SPECIFICATIONS ARE SUBJECT TO CHANGE WITHOUT NOTICE

Distributed by:

GULLCO

GULLCO INTERNATIONAL LIMITED - CANADA

Phone: 905-953-4140 Fax: 905-953-4138 e-mail: sales@gullco.com

GULLCO INTERNATIONAL INC. - U.S.A

Phone: 440-439-8333 Fax: 440-439-3634 e-mail: ussales@gullco.com

GULLCO INTERNATIONAL (U.K.) LIMITED- EUROPE

Phone: +44 1257-253579 Fax: +44 1257-254629 e-mail: sales@gullco.co.uk

GULLCO INTERNATIONAL PTY LIMITED - AUSTRALIA

Phone: 61 (0) 7 5439-0701 Fax: 61 (0) 7 5439-0704 e-mail: ausales@gullco.com

GULLCO INTERNATIONAL INDIA PVT LIMITED - INDIA

Phone: 91-20-65260382 Fax: 91-20-26836656 e-mail: india.io@gullco.com

GULLCO INTERNATIONAL SHANGHAI LIMITED- CHINA

Phone: +8621-50460341 Fax: +8621-50463554 e-mail: gsuntech@sh163.net

GULLCO INTERNATIONAL LIMITED- LATIN AMERICA

Phone: 55-11-9485-1336 e-mail: rogerio.macedo@gullco.com

STUCH GMBH & CO. KG SCWEISSTECHNIK - GERMANY

Phone: (02 03) 72 94 95 Fax: (02 03) 72 94 96 e-mail: info@stuch-schweisstechnik.de

WWW.GULLCO.COM

PS-10-01-L