

INVERTEC® 161S

Spare Parts	1
Figure A: Machine Assembly	2
Figure B: Inside Machine Assembly	3
Electrical Schematic	4
CODE: 50572	4



Spare Parts

SP50572 REV00
11/2019

ASSEMBLY PAGE NAME			Machine Assembly	Inside Machine Assembl	Inside Machine Assembly	Front Assembly	Miscellaneous Items	
CODE NO.:	K NO.:	FIGURE NO.:	A	B	C	D	-	
50572	K14293-1	INVERTEC® 161S	1	1	-	-	-	

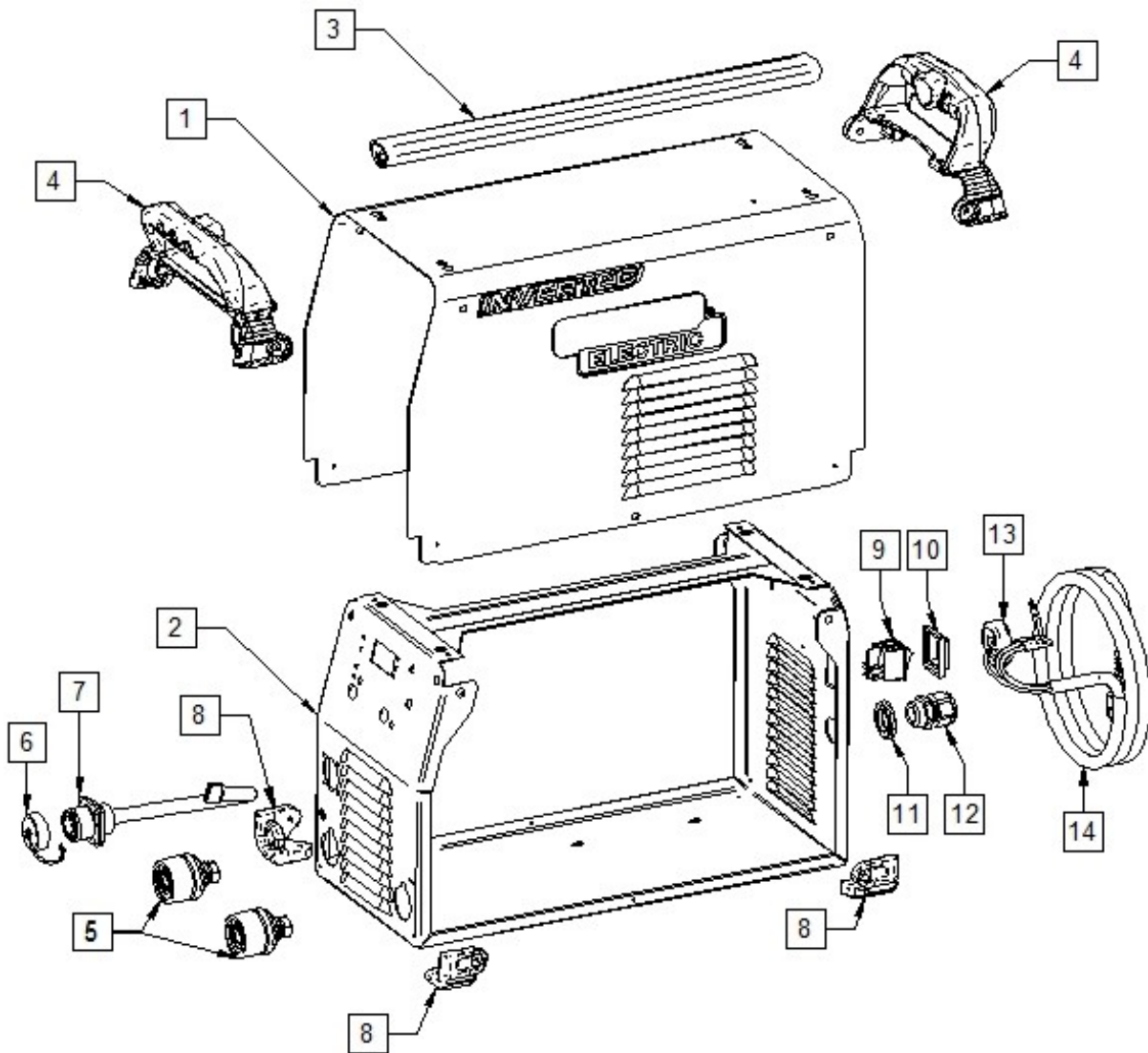

Figure A

Figure A: Machine Assembly

Item	Description	Part Number	QTY	1	2	3	4	5	6	7
1	COVER	R-1012-932-1R	1	X						
2	BOTTOM	R-1012-923-2R	1	X						
3	HANDLE L= 418 mm	W92X0228-8R	1	X						
4	HANDLE CASE	W95X1387R	2	X						
5	QUICK SOCKET FOR PANEL	W7690350R	2	X						
6	PROTECTION COVER PLUG AMP	1158-641-128R	1	X						
7	SOCKET MS3102A-18-12S	1158-641-008R	1	X						
8	CORNER CAP CASE A-B	W95X1149R	4	X						
9	SWITCH	W000352016	1	X						
10	WATERPROOF CAP	1115-299-225R	1	X						
11	KNOB CABLE CLAMP	W000352033	1	X						
12	CABLE CLAMP	W000227612	1	X						
13	TOROIDE 3C90 TN32-19-13	033505006R	1	X						
14	INPUT CABLE 3X2.5MM2 3.3M	W000274825	1	X						

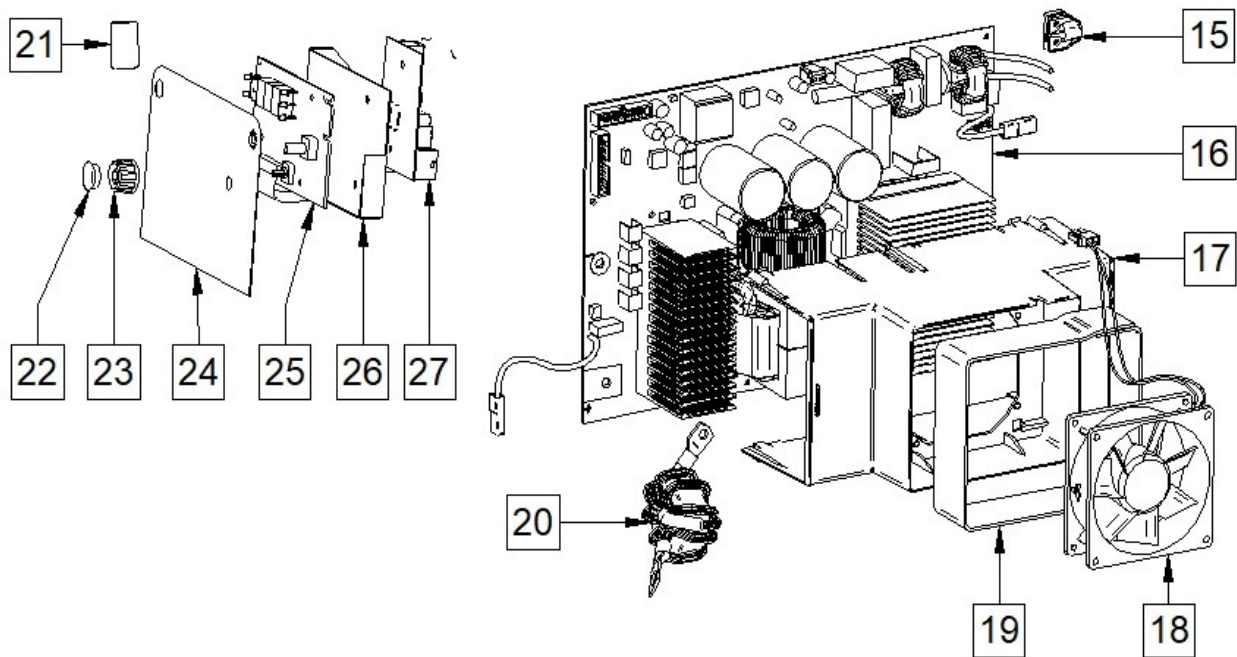

Figure B

Figure B: Inside Machine Assembly

Item	Description	Part Number	QTY	1	2	3	4	5	6	7
15	BLOCK FIXING	W000352073	3	X						
16	PCB 800022734E with varistor	R-6240-004-1R	1	X						
17	AIR CONVEYOR 92X92	W000270555	1	X						
18	FAN 073010046 WITH CONNECTOR	W000376266	1	X						
19	ADHESIVE EXTENSION PVC	800035769R	1	X						
20	COIL 180A	W000270556	1	X						
21	FERRITE CORE 260-6795 3W80017,5X9,5X28,5	1158-290-036R	1	X						
22	HOOD	W000352077	1	X						
23	KNOB Ø 21	W000352038	1	X						
24	FRONT LABEL	R-0010-720-2R	1	X						
25	CIRCUIT BOARD CE 22688	W000264772	1	X						
26	SHIELD CONTROL PANEL	R-1010-078-2R	1	X						
27	PCB INTERFACE	W000275004	1	X						

Electrical Schematic
CODE: 50572

